



MAINERO



FORAGE HARVESTER
MAINERO

 **U-150-B**

www.mainero.com



Tractor requirement	
Minimum power:	40 CV
Hydraulic system:	Does not require.
Electric system:	Does not require.
Power take off:	540 rpm
Transmission	
Drive:	Protected PTO shaft. With constant velocity joint.
Transmission gear box type:	Combined to drive the mechanical coupling without uncoupling the machine. Gears of alloy steel treated in oil bath.
Gear drive:	Mechanical, operated from the tractor
Chopper rotor	
With oscillating blades:	
Cutting width:	1.500 mm
Amount of blades:	20
Type of blades:	With special treatment and hard armored on its edges
Rotation speed:	1.500 RPM
Drive:	"V" belts. Quantity 4
Cutting height:	Adjustable between 0 and 300 mm
Cutting height adjustment:	Combined from Wheel axle and front register.
Loading tube	
Rotation drive:	Manual, operated from the tractor.
Visor drive:	Manual, operated from the tractor.
Rotation angle:	180°, operated from the tractor.
Loading tube valve	
Adjustable for loading of mechanical or weeding trailer	
Drive:	Manual
Draw bar	
Type:	Adjustable for working - transport.
Drive:	Manual
Wheel axle	
2 independent arms with height register.	
Tires:	6.00 - 16. quantity 2
Weight	870 Kg

Dimensions	
Length (A):	3.170 mm
Width (B):	2.700 mm
Height (c):	3.180 mm
Optional:	Transmission elements and hitch for forage wagon.

The Company reserves the right to make changes to its products without prior notice.

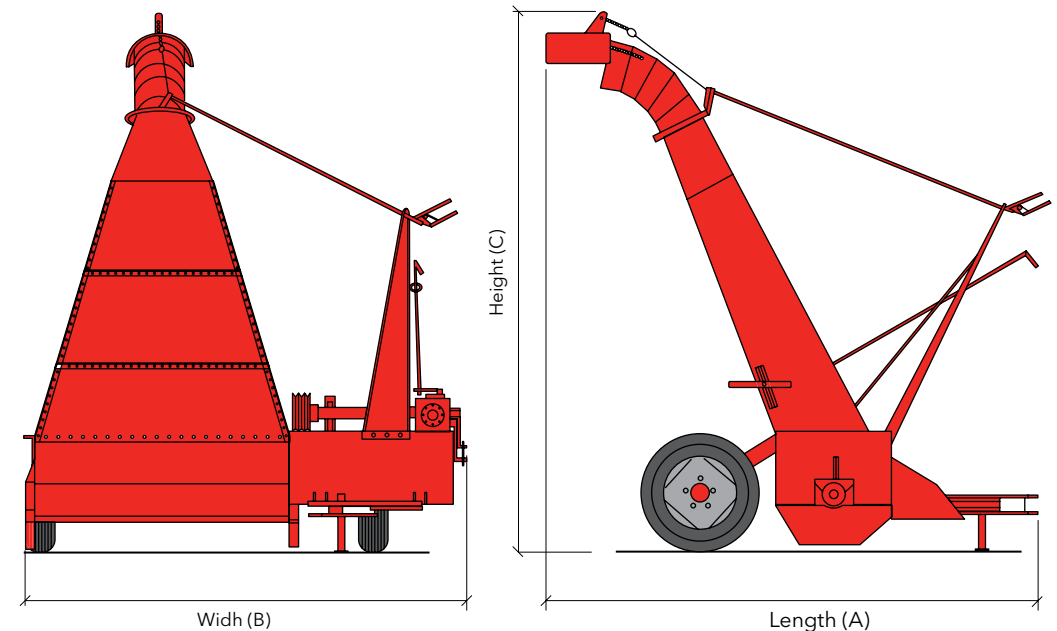

www.mirruono.com

